

Sport 250RR

Megelli

User Manual

Preface

Congratulations on the purchase of your new Megelli. We thank you for choosing our product and take this opportunity to welcome you to Megelli motorcycles.

This booklet is an integral part of your motorcycle and should remain with the bike for the duration of its life.

We ask you to read the contents and ensure you are familiar with the maintenance, controls and safety aspects of the bike prior to riding. Should you have any questions regarding its function or operation, please contact a Megelli authorized dealer.

The content of the manual represents the Sport 250RR motorcycle. Megelli reserves the right to introduce changes to the product as part of its commitment to a program of continuous improvement.



Contents

	<u>Page</u>
<u>Introduction</u>	7
➤ Bike detail	
<u>Identification</u>	8
<u>Delivery</u>	10
➤ PDI	
➤ Records	
<u>Controls/Features</u>	11
<u>Safety-General</u>	26
<u>Safety/Pre-Ride Checks</u>	27
➤ Rider	
➤ Bike	

Contents

<u>Operation</u>	30
➤ Starting the Engine	30
➤ Stopping the Engine	32
➤ Running in	33
➤ Riding	34
➤ Braking	35
➤ Gear selection/Riding	36
➤ Steering lock	37
➤ Side Stand	38
➤ Fuel Tank	39
➤ Seat Removal	40
<u>Maintenance</u>	41
➤ Service Schedule	42
➤ Access	43
➤ Engine	44
➤ Chain Adjustment	45

Contents

➤ Brakes	47
➤ Clutch	51
➤ Suspension	52
➤ Lubrication	54
➤ Battery, Electrical	55
➤ Lights	57
➤ Air Filter	62
➤ Wheels/Steering	63
➤ Tyres	65

Technical Specification..... 66

➤ Engine	66
➤ Transmission	67
➤ Electrical	68
➤ Dimensions	69
➤ Chassis/Wheels/Tyres	70
➤ Capacities	71
➤ Fluid Grade	72

Contents

<u>Cleaning/Care</u>	73
<u>Storage</u>	75
<u>Warnings</u>	76
<u>Environmental</u>	77
<u>Parts</u>	78
<u>Warranty</u>	79

Introduction

The Megelli bike conforms to legislation of construction, operation, design and emissions, as required for use on public highways.

There is provision for a single rider plus a pillion. It is equipped with a 4-stroke, air cooled engine with a battery operated electric start function. The transmission has 6 manually selected gears with a chain drive to the rear sprocket.

The frame has a twin trellis construction with alloy outriggers and a tubular constructed rear swing arm.

Hydraulic 38mm forks are utilized for the front suspension with a mono-shock absorber for the rear.

Braking is via hydraulically operated front and rear disc brakes.

Identification

Each bike has an individual chassis number which is engraved on the headstock of the frame:

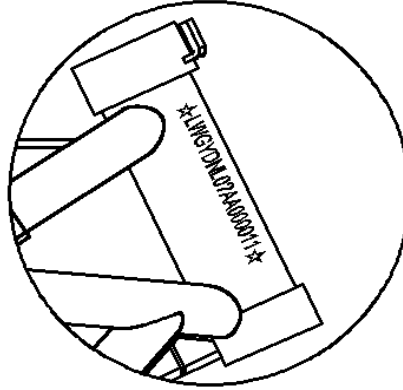

and a unique engine number engraved on the casing of the engine:



Identification

These numbers correspond to the details on the Pe-Delivery Instruction (PDI) and Warranty Manual. It is advisable to make a note of these numbers and keep them in a safe location for future reference.

There is also a plate riveted to the chassis with details specific to the individual model and bike:
(Note: This plate may be in a different format in regions outside of Europe)

Delivery

Prior to receiving your new Megelli motorcycle, the supplying dealer will have conducted a Pre-Delivery Inspection (PDI) of the bike. Please ensure you are entirely satisfied with the condition of the motorcycle, the terms of the warranty, service schedule and the operation of the controls has been explained. A copy of the form with a list of completed checks will be passed to you once it has been signed and dated by both the dealer and purchaser of the bike.

You should also remember your responsibility to ensure any legal requirements to permit usage on the highway are in place before riding. For example tax, insurance, number plates, etc.

Controls/Features

R/H Side View

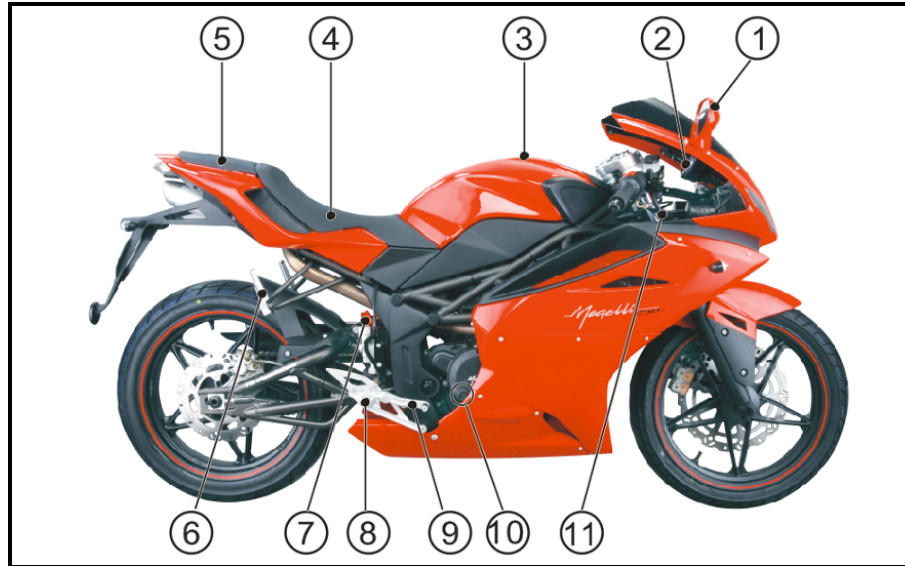

KEY

- 1. R/H Rear View Mirror
- 2. Instrument Panel
- 3. Lockable Fuel Cap
- 4. Rider Seat

- 5. Pillion Seat
- 6. R/H Pillion Footrest
- 7. Rear Suspension
- 8. R/H Rider Footrest

- 9. Rear Brake Pedal
- 10. Oil Level
- 11. Front Brake Lever

Controls/Features

L/H Side View

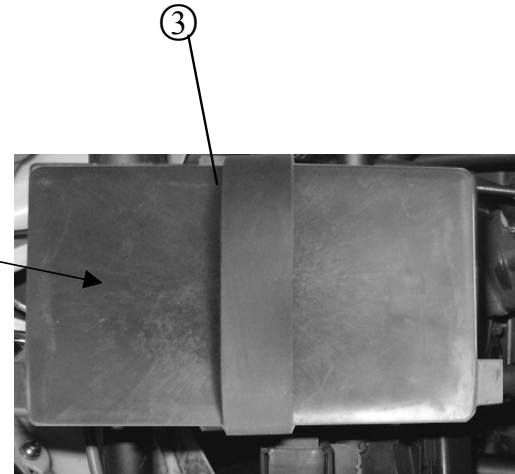
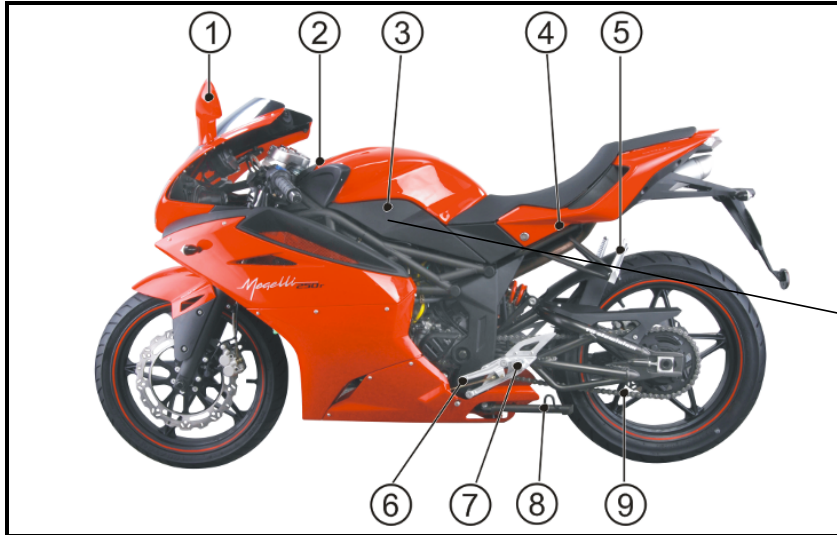

KEY

- | | |
|---------------------------------|-----------------------|
| 1. L/H Rear View Mirror | 6. Gear Lever |
| 2. Steering Lock | 7. L/H Rider Footrest |
| 3. Battery (under fuel tank) | 8. Side Stand |
| 4. Air Filter (under seat unit) | 9. Chain |
| 5. L/H Pillion Footrest | |

Controls/Features

Left-Hand Switch/Handlebar Assembly

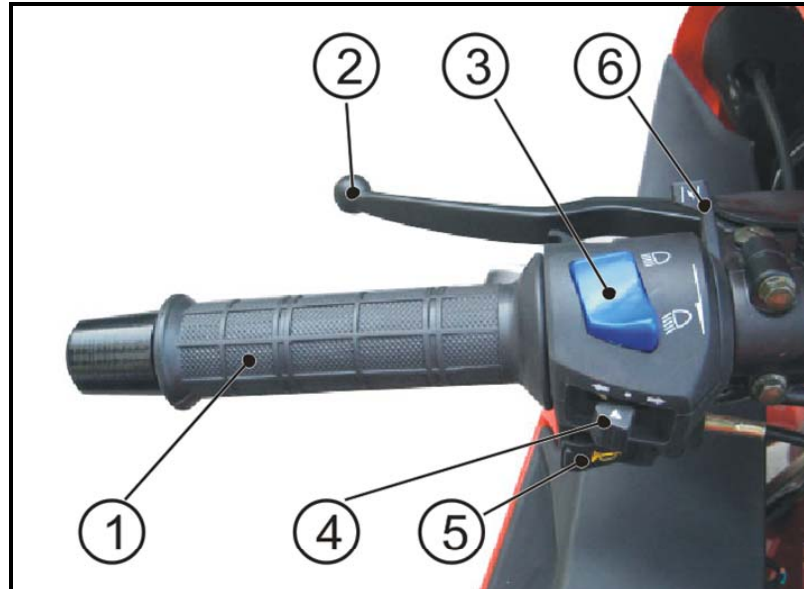

KEY

- | | |
|-------------------------|---------------------|
| 1. Hand Grip | 4. Indicator Toggle |
| 2. Clutch Lever | 5. Horn Switch |
| 3. High-Low Beam Switch | 6. Choke Lever |

Controls/Features

Clutch Lever:

To disengage the clutch allowing gear selection, pull the lever towards the hand grip.



To engage drive, release the lever smoothly to prevent transmission damage .

Controls/Features

High-Low Beam Switch:

Position 1=Low Beam

Position 2=High Beam

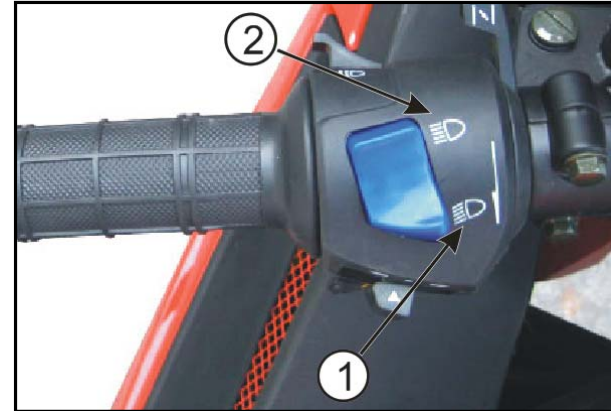

Indicator Toggle:

Position 1=Turn Left

Position 2=Turn Right

Push to Cancel

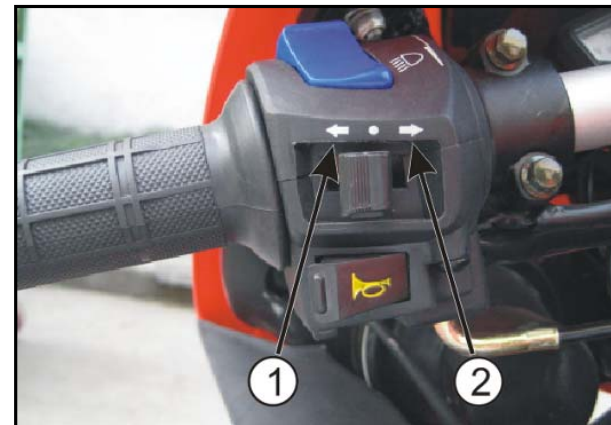

Controls/Features

Horn:

Push button to activate



Choke Lever:

Move the lever in direction A to activate the choke

Move the lever in Direction B to disengage the choke

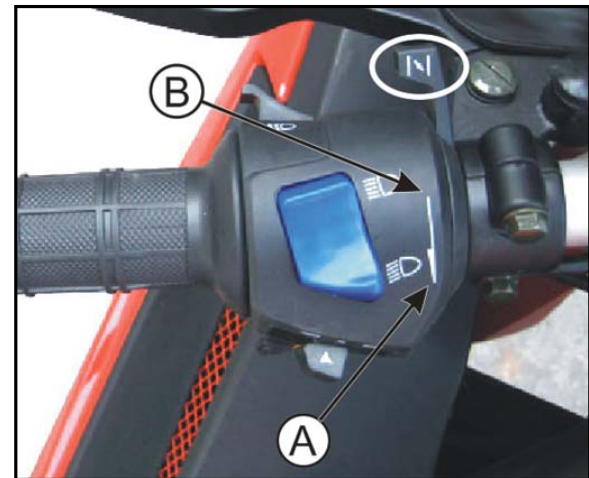

Controls/Features

Right-Hand Switch /Handlebar Assembly.

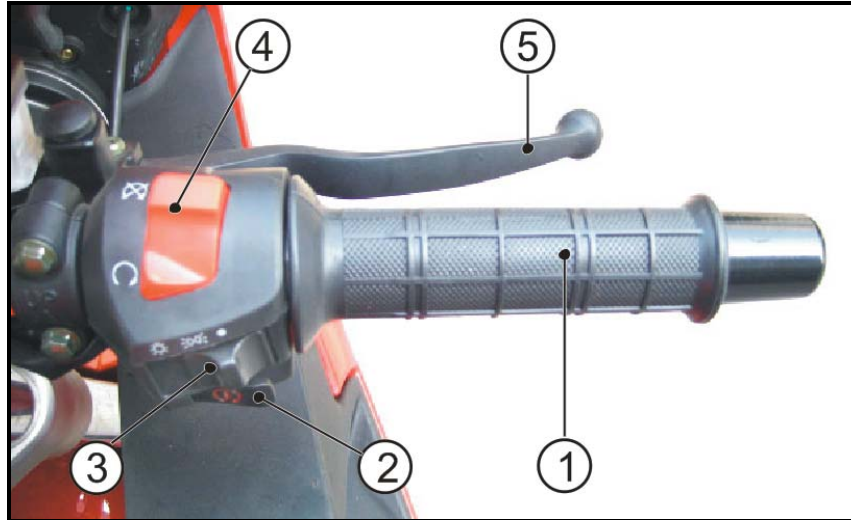

KEY

1. Throttle Grip
2. Starter Button
3. Light Switch
4. Engine Kill Switch

5. Front Brake Lever

Controls/Features

Light Switch:

Position 1=Lights Off

Position 2=Side Lights On

Position 3=Headlight On

Note. Operation may vary in countries where their laws require.

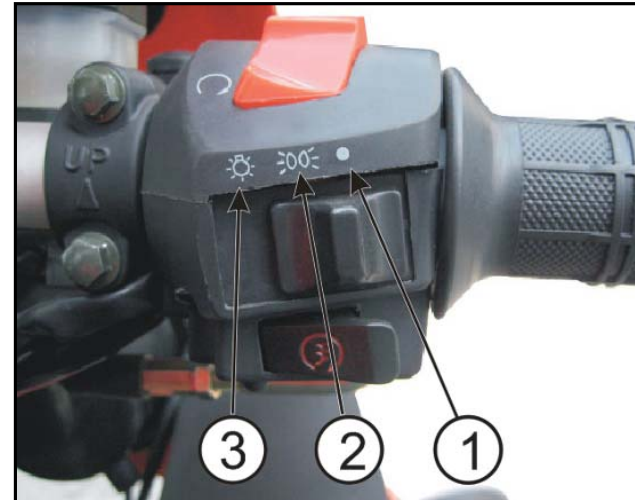

Controls/Features

Throttle:

Rotate anti-clockwise to increase the revs

Rotate clockwise to reduce the revs.

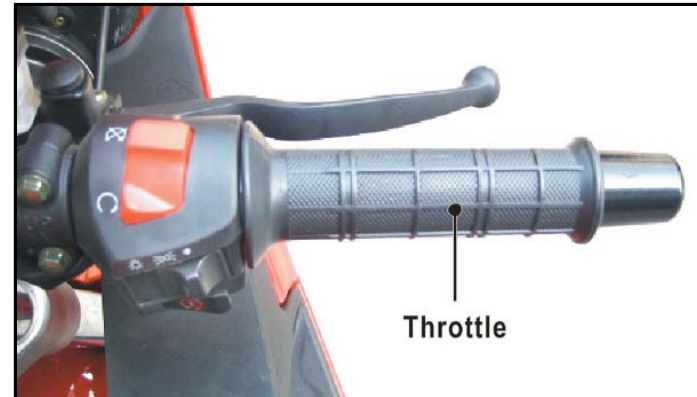

Starter Button:

Press to activate starter. Release as soon as engine fires

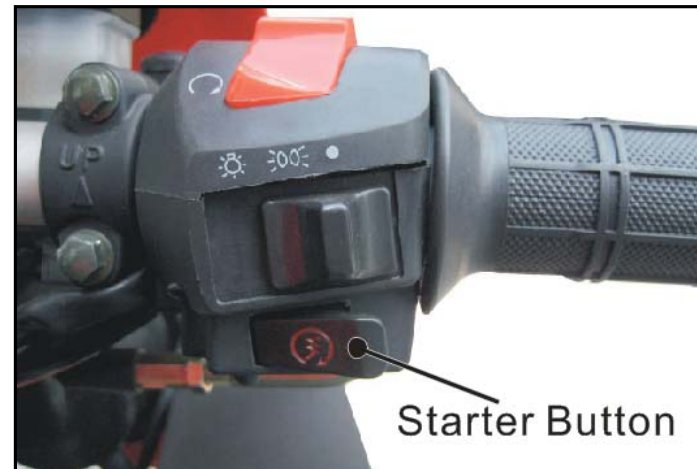

Controls/Features

Kill Switch:

Switch to 'Run' position for engine to start/run

Switch to 'Kill' position to stop engine in an emergency



Front Brake Lever:

Pull lever towards handlebar with a smooth, but positive action to apply the front brake.



Controls/Features

- Indicator lights**
- Battery voltage alarm (Red)
 - Direction light (Green)
 - Neutral light (Green)
 - High beam light (Blue)
 - Water temperature (Red)
 - Fuel alarm (Yellow)

Press the **Adjust button** in main screen to switch from odometer, trip meter and MAX record.



Press the **Adjust button** X 3 seconds in MAX record screen to reset the record.



Tachometer warning light

- 10,000 RPM.



Speedometer

- Display range: 0~200 km/h. 0~124 MPH.
- Display unit: km/h or MPH.

Odo meter

- Display range: 0~99999.9 km (mile), reset automatically after 99999.9 km.
- Display unit: 1 km (mile).

Trip meter

- Display range: 0~999.9 km (mile), reset automatically after 999.9 km.
- Display unit: 0.1 km (mile).

- Clock**
- 24H

Tachometer

- Display range: 0~12,000 RPM.
- Display unit: 100 RPM.

Controls/Features

Ignition Switch/Keys:

2 keys are supplied .

Position A=Ignition Off.

Position B=Ignition On-Circuits Activated.

Position C=Steering Lock-Push and turn anti-clockwise with steering on full lock.

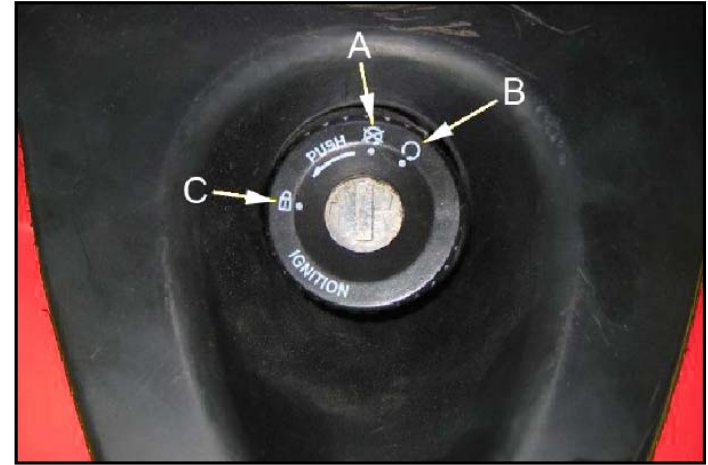

▲ **Warning** - Do not switch ignition off while riding.

Rev Counter:

Indicates the number of revolutions per minute (rpm).

!Caution - Never run the engine with the rpm in the red sector- a red warning light will illuminate.

!Caution - Refer to the 'Running in' section for maximum rpm.

Green Turn Indicator:

Flashes when L/H or R/H indicator position is selected.

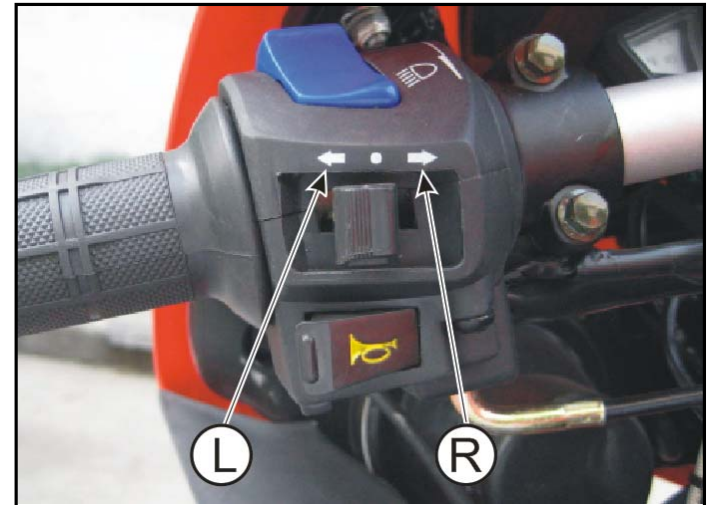

Controls/Features

Odometer/Tachometer:

Records accumulative distance traveled. Note: this should be set as either miles or km's depending on relevant country requirements.

Trip Meter:

Records distanced traveled and can be re-set to zero when required.

Press adjust button to access from odometer → trip meter → max record.

Blue Full Beam Lamp:

Illuminates blue when the high beam position is selected.

Amber Low Fuel Warning:

Illuminates when there is approximately. 1 litre of fuel remaining in the tank.

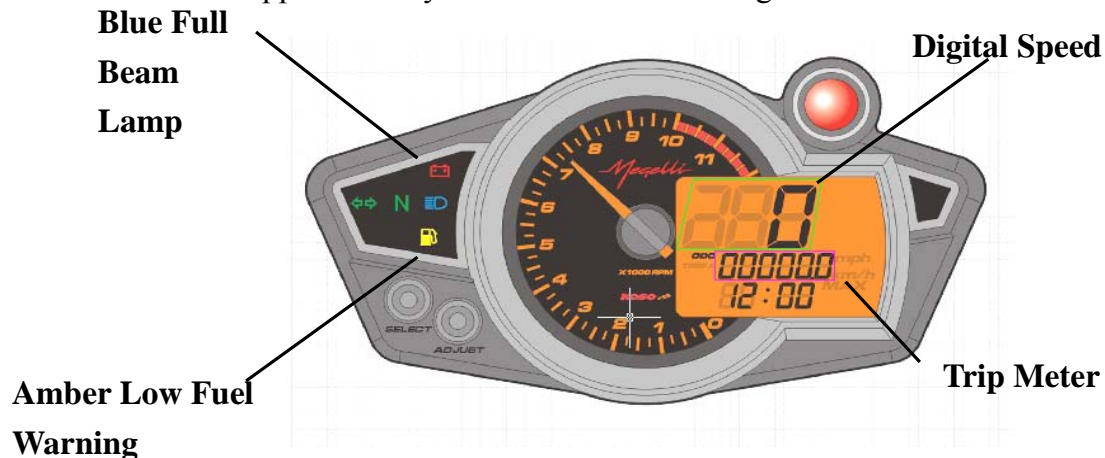

Controls/Features

Clock Digital display:

- Press the 'select' button for 3 seconds to enter the hour adjusting mode.
- Pressing the 'select' button repeatedly will increase the hour digit (24 hour clock).
- Press the 'adjust' button to enter the minute adjusting mode.
- Pressing the 'select' button repeatedly will increase the minute digit.
- Press the 'adjust' button to save and exit the clock setting mode and return to the main screen.

Neutral Light:

When the neutral position is selected, the 'N' green light will illuminate.

Odometer:

Records the accumulative distance traveled. Note this should be set as either miles or km's depending on relevant country requirements.

Controls/Features

Trip Meter:

Records distance traveled.

- Press the 'adjust' button to enter the Trip Meter display.
- Press the 'adjust' button for 3 seconds to set the display to zero.
- Press the 'adjust' button twice to return to the main screen.

Max Record:

Records the maximum speed traveled.

- Press the 'adjust' button twice to enter the maximum speed display.
- Press the 'adjust' button for 3 seconds to set the display to zero.
- Press the 'adjust' button once to return to the main screen.

Battery Light:

Illuminates red when there is insufficient charge to the battery.

Safety-General

- ▲ Warning-Never touch engine or exhaust when they are still hot.
- ▲ Warning-Always keep body extremities and clothing away from any moving part.
- ▲ Warning-Do not expose unprotected skin to fluids used in the motorcycle. When working with such fluids, always use protective clothing.

! Caution - Motorcycles are heavy and should be handled with care to avoid injury.

Always seek assistance when required.

Safety/Pre-Ride Checks

Safety First:

Rider-Prior to riding the bike.

- Ensure you have received adequate training on riding skills and knowledge of highway rules and regulations.
- Familiarize yourself with the controls of the bike and ensure that you have fully read and understood the manual.
- If you are unclear or unsure of any aspect, seek the assistance of a qualified Megelli agent or instructor.

- Protective clothing should be worn while riding the bike. This should include an approved helmet and appropriate apparel.

- No additional items should be carried on the bike which may impede access or operation of the controls or make the bike un-balanced.

Safety/Pre-Ride Checks

- Always ride within your limits and experience.
- Always keep your feet placed on the footrests and your hands on the handlebar grips.
- Pillion passengers must always keep feet placed on the footrests.
- Do not attempt to alter settings on the instrument console while riding.
- Do not overload the bike. Adjust tyre pressures and suspension settings to suit the loading of the bike.
(see tyre pressure, suspension settings & loading capacities).
- Do not ride while under the influence of drugs, alcohol or any medication which may adversely affect your reactions.
- Take account of the road conditions and ride accordingly, reducing speed if necessary.
- Ensure the bike is road worthy and all lights are clear from dirt.
- Adjust the rear view mirrors to suit the rider.
- Do not ride off-road.

Safety/Pre-Ride Checks

Bike-Prior to riding the bike on every journey, check:-

- Ensure sufficient fuel to complete journey or reach the next fueling station.
- Oil level (see page 44).
- Brake fluid level(see page 49&50).
- Tyre pressure (page 70).
- Tyre tread and condition(see page 65).
- Lights, indicators and horn are functioning correctly.
- Brake operation/Brake pad wear (see page 35 & 47).
- Steering is smooth from lock to lock.
- Suspension is operational without fluid leaks.
- Chain adjustment/lubrication(see page 45 & 46).
- Side Stand is fully retracted (see page 38).
- Ensure the bike has not been modified in any way including the addition of accessories other than official Megelli items.
- All fixings are in place and secure.
- As the engine warms, gradually move the choke lever to the 'Off' position.

Operation

Starting the Engine

When the bike is new refer to page 33 for running in guide.

To start the engine, follow the following procedure:

- Ensure there is adequate ventilation.
- Conduct all safety and routine maintenance checks (refer to Safety/Pre-Ride Checks).
- Release the steering lock mechanism (refer to Steering Lock, page 37).
- Mount the bike.
- Switch the 'Kill Switch' to run/on position (page 32).
- Insert the ignition key and turn to the 'On' position.
- Allow the self check system to complete its cycle.
- Check the 'Green Neutral' indicator light is illuminated and roll the bike forward ensuring the transmission is in the neutral position.

Operation

- When starting from cold, move the choke lever to the 'On' position. If the engine is warm, leave the choke lever in the 'Off' position.
- Push the starter button and apply the throttle (turn anti-clockwise) when engine fires.
- As soon as engine fires, release the starter button and allow the bike to idle (turn the throttle fully clockwise).
- Should the engine not start after 10 seconds, release the starter button and repeat the procedure after waiting for 10 seconds.

As the engine warms; gradually move the choke lever to the 'off' position.

Operation

Stopping the Engine

When you have completed the ride and wish to switch the engine off, follow the procedure:

- Park the bike in a position where the heat from the engine and exhaust will not cause any damage or the likelihood of people/children touching these parts is minimal.
- Select an area of level ground which is firm to avoid the side stand sinking under the weight of the bike.
- Select neutral position and check the green neutral indicator is illuminated.
- Turn the key to the 'off' position.
- Move the side stand to the down/park position and gently lean the bike on the stand.
- Apply the steering lock-refer to page (page:37).

Operation

Running In

When an engine is new, it must be 'run in' for a period to reduce the amount of wear on the engine, transmission and brakes. This allows the moving parts to become polished and 'bedded in', which will extend the life of the engine. During this period, also avoid harsh acceleration.

▲ **Warning.** For the first 300 km's (200 miles) do not operate the engine for long periods above 4500 rpm. During the running in period, or when replacement brake pads are fitted, avoid harsh, prolonged or excessive braking. This will allow the pads to be 'bedded in' and the braking performance will be improved.

▲ **Warning.** During the running in period, greater pressure on the brake levers will achieve the same braking performance.

Operation

Riding

While riding, always ride within your ability and take account of the conditions, including road surfaces and the weather.

!Caution Remember visibility can be reduced in poor weather conditions and braking distances increase on wet and slippery road surfaces.

The style and manner in which you ride will affect aspects such as fuel consumption and the amount of wear on components of the bike. By avoiding excessive acceleration, engine revs and shifting quickly up through the gears the fuel consumption will be reduced and this will also reduce the wear on the engine, brakes and tyres.

Operation

Braking

- Avoid oil, grease or any lubricant contaminating the friction surfaces of the braking system as this will adversely affect the braking performance.
- If the bike has been ridden in wet conditions, been washed or has not been used for a long period allowing corrosion of the discs, apply the brakes gently, several times to clear the friction surfaces.
- Apply both the front and rear brakes to improve braking performance and reduce the chance of a wheel locking & skidding.

▲ **Warning.** Always check operation of the braking system prior to riding.

Operation

Gear Selection/Riding

Prior to riding, ensure the spring activated side stand is fully retracted to its stowage position.



To select the gears, disengage the clutch (pull fully towards the hand grip) and move the gear selector from the neutral position, down, to 1st gear position. Release the clutch lever smoothly while applying the throttle at the same time.

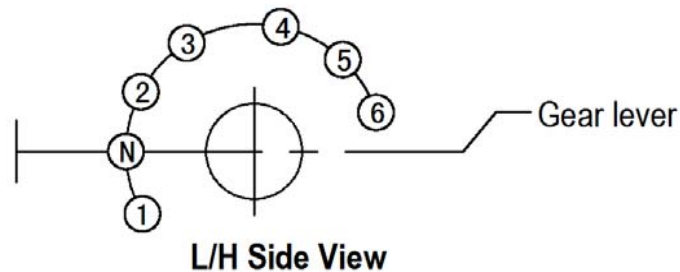

Operation

Steering Lock

Always apply the steering lock when the bike is left unattended to reduce the risk of theft. The lock is located on the headstock and is applied by the ignition key



To operate the lock, turn the steering fully to the left and then insert the ignition key. Depress the key and turn anti-clockwise to apply the lock.

To release the lock, insert the key and turn it clockwise and remove the key. The steering is now free to be turned.

Operation

Side Stand

The side stand supports the bike when not being ridden. The stand returns automatically to its stowage position when the bike is moved upright and the weight is removed from the stand.

▲ **Warning** - Ensure no part of your body is in the arc that the stand swings through on its return to the stowage position as it returns with considerable force.

! **Caution** - Check the stand returns fully to its stowage position before riding.

Riding with the stand fully or partially down is unsafe.

To apply the stand, move the stand fully forward with your foot against the pressure of the spring. At the same time, gently lean the bikes onto the stand until it takes the full weight.

Always turn the steering fully to the left.

Operation

Fuel Tank

To open the fuel cap, lift the hinged fuel cap cover through 90° and insert the key. Turn the key anti-clockwise to release the lock allowing the cap to be opened.

To close the fuel cap, push the cap into position and turn the key clockwise, engaging the lock. The key can now be removed and the cover closed.



▲ **Warning** - Ensure the cap is correctly closed before riding.

Operation

Seat Removal



To remove the seat, insert the key into the seat lock and turn clockwise to release the lock. Lift and pull the rear seat towards the rear of the bike as a single operation.

To replace the seat, align the guides at the front of the seat with their respective locations.

Lower and move the seat forward as a single operation until fully forward. At this point, press firmly at the back of the seat until it clicks and then remove the key.

! **Caution** - ensure the seat is correctly fitted before riding the bike.

Maintenance

It is essential your Megelli bike is serviced by an authorized Megelli retailer in accordance to the schedule. In addition to this, basic checks and adjustment should be made periodically by the rider.

! Caution-If you are unsure of how to perform any adjustments/checks or do not have the correct tools, consult a Megelli technician.

Your bike should also be kept clean and free from dirt, and also be correctly lubricated.

! Caution – Do not use high pressure washer systems to clean your bike as this could cause water ingress into electrical and fuel systems. It may also remove essential lubricants.

Maintenance

Service Schedule

For the services to be conducted by an authorized Megelli dealer, please refer to the separate Service/Warranty booklet.

Additional checks are required periodically as part of the routine maintenance and are listed in this manual.

Maintenance

Access

Once the seat has been removed (see seat removal page 40) all areas which require daily or weekly attention are accessible without the need to remove any further panels or bodywork.

Maintenance

Engine

➤ Oil level

This should be checked daily. Ensure the bike is on level ground and upright for this operation. The oil level must be between Up and Low marks.

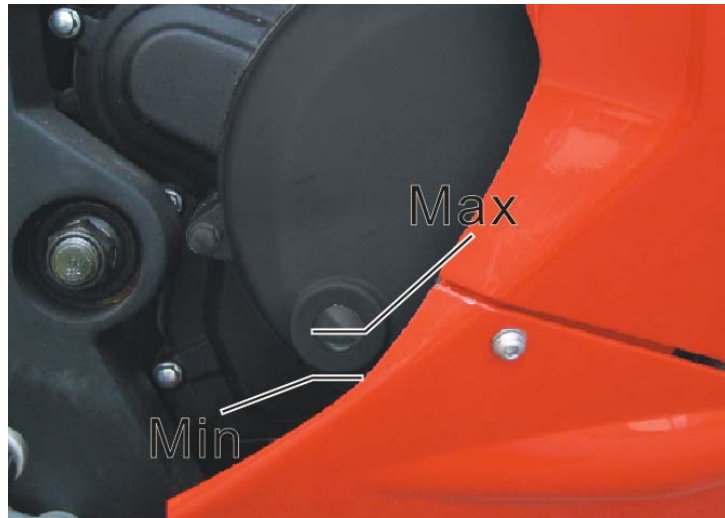

▲ Warning If the oil level is either too high or too low, the engine may be seriously damaged.

Maintenance

Chain Adjustment

- 1) Secure the bike so the rear wheel is clear of the ground and can turn freely.
- 2) Loosen the rear axle.
- 3) Loosen the locking nuts from the chain adjuster.
- 4) Screw the adjusting bolts, allowing the rear wheel to move further from the bike, thus tightening the chain.
Adjustment should be equal on both sides. Marks on the swing arm assist in this operation.
- 5) Correct tension is achieved when the chain can be flexed 15-25mm at point A.

Maintenance

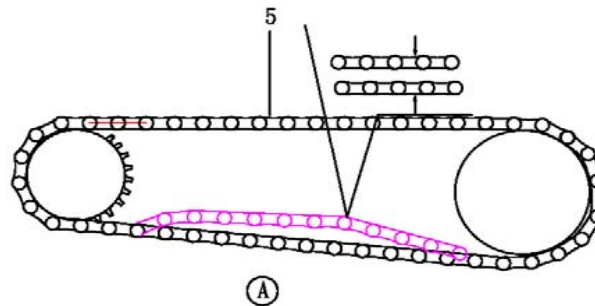
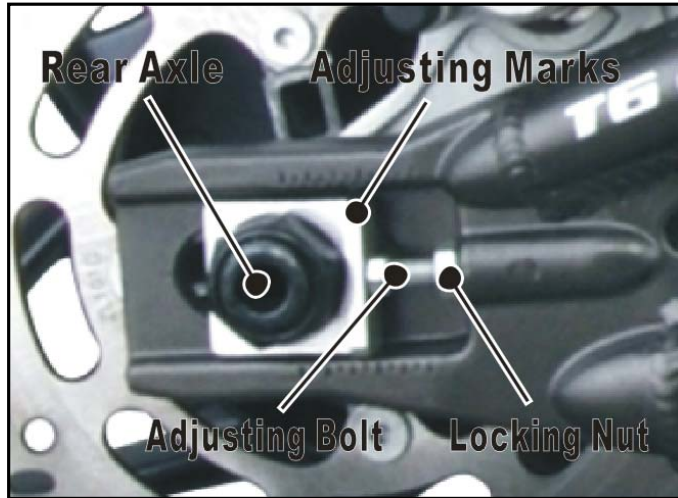

▲ **Warning** If the chain is incorrectly adjusted, the motorcycle may be damaged and the life expectancy of the chain reduced.

Maintenance

Brakes

- 1) The brake linings should be free from corrosion.
- 2) Check the thickness of the brake pads. If there is less than 1.75mm of friction material left, the pads should be replaced by a Megelli authorized dealer.

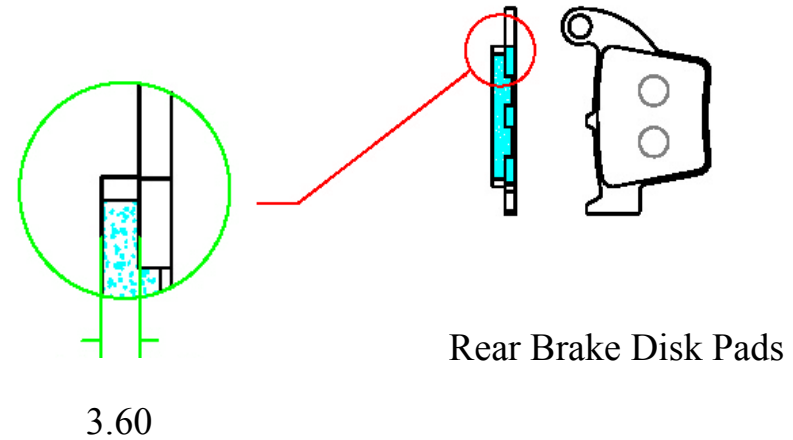
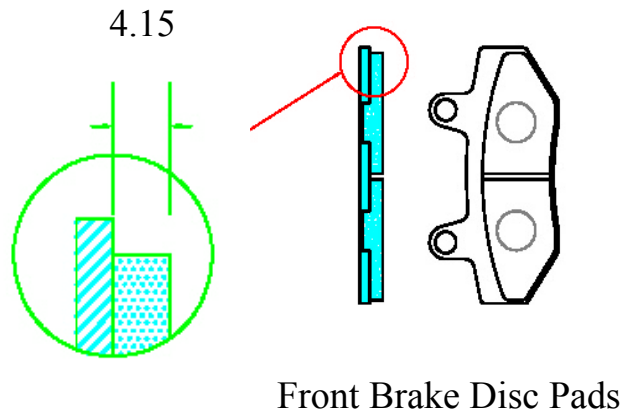

Maintenance

- 3) Check the thickness of the brake discs. If they are damaged or the thickness is less than 3.5mm, have them replaced by a Megelli authorized dealer.

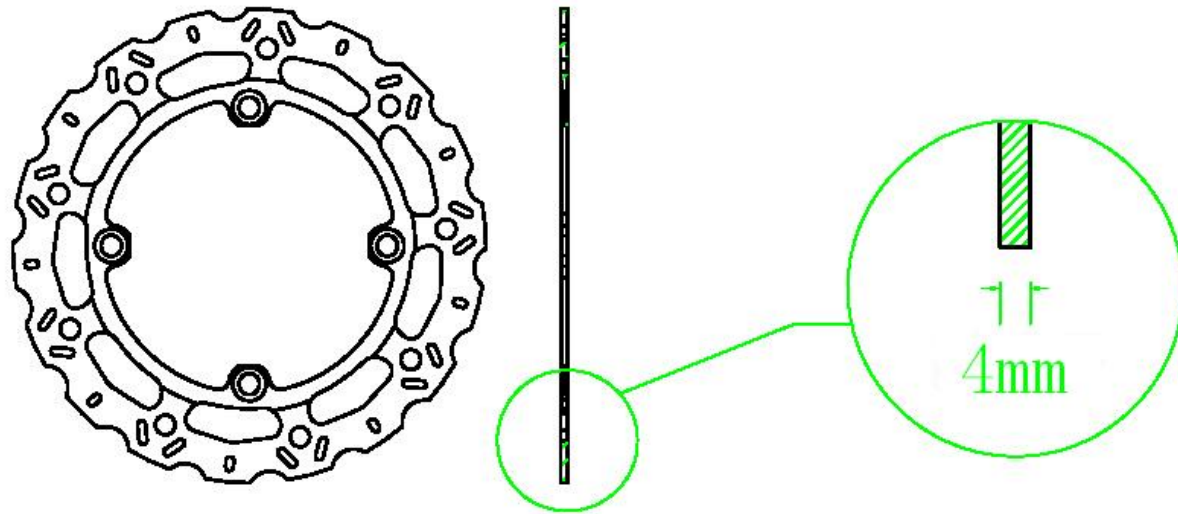

Maintenance

Front Brake Fluid Check:

- 4) The front brake fluid level must be checked daily. With the bike on level ground and upright, the fluid level in the front master cylinder reservoir must be between the minimum, and maximum marks.

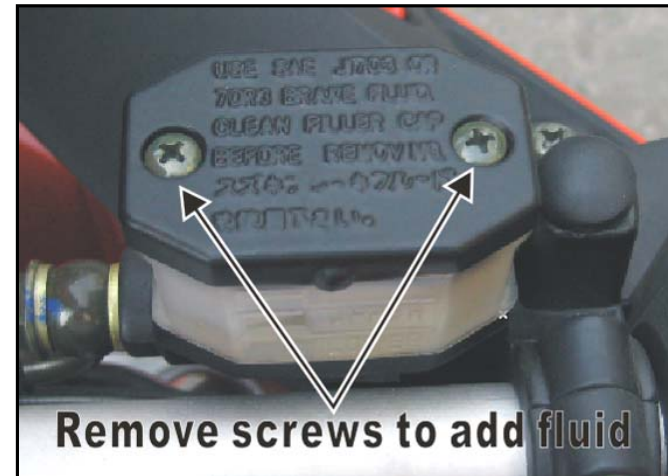
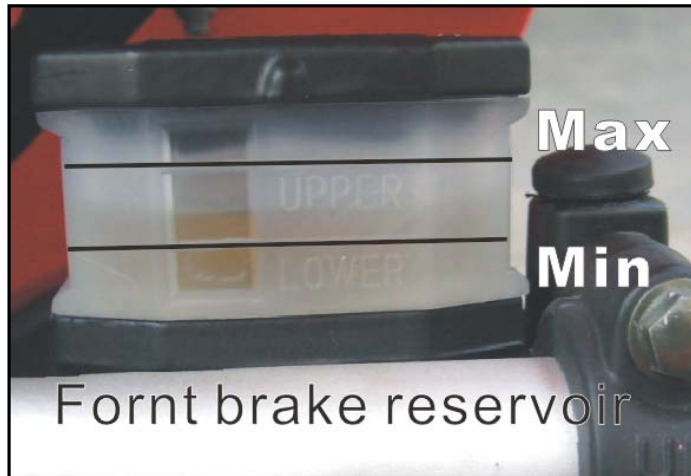

If the level is low, check the system for leaks. To add fluid, remove the lid secured by 2 screws. Always use fluid from a sealed source.

Maintenance

Rear Brake Fluid Check

The fluid level on the rear reserve (incorporated into the rear master cylinder) must be central in the viewing glass.

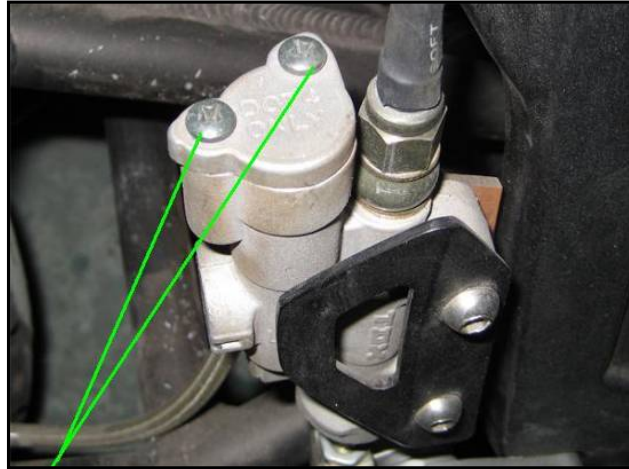

REMOVE SCREWS TO ADD FLUID

If the level is low, check the system for leaks. To add fluid, remove the lid secured by 2 screws. Always use fluid from a sealed source.

Maintenance

Clutch

The clutch lever should have 2-3mm of free play (movement before the clutch starts to be activated).

To adjust the cable:

- 1) Loosen the locking nut
- 2) Turn the adjusting nut to achieve correct free play.
- 3) Tighten lock nut



▲ **Warning** An incorrectly adjusted clutch will reduce its life expectancy and affect the performance of the motorcycle

Maintenance

Suspension

The suspension should be checked for leaks and general condition.

The rear suspension can be altered to suit the individual rider and loading of the bike.

Spring adjustment:

- a) Using a 2.5mm allen key, release the locking screw on the adjusting nut.
- b) Using an appropriate special tool, turn the adjusting nut clockwise to increase the pre-load (harden the suspension) or anti-clockwise to decrease the pre-load (soften the suspension):
 - 1) Locking screw
 - 2) Adjusting nut
 - 3) Tool for turning adjusting ring



Maintenance

Suspension

Using a pump designed for high pressure associated with shock absorbers, add or reduce the air pressure. Recommended air pressure is 150psi.

! Caution - the shock absorber contains pressurized gases and the spring is under considerable pressure. It is important to exercise caution when handling this component. If in doubt, contact a Megelli dealer.

Maintenance

Lubrication

Chain - Adequate lubrication of the drive chain is crucial to maintaining its working life expectancy.

▲ **Warning** Insufficient lubrication will increase the chance of the chain seizing and causing further problems with potential financial and safety consequences.

Use a lubricant specifically for chains which can be supplied by Megelli outlets. The frequency of lubrication is dependant on the amount of use and the conditions the bike is ridden in. As a guide, a weekly lubrication is required for a bike used regularly, but every time after washing or riding in the rain.

Cables - The cables should be checked, prior to each ride, ensuring they operate smoothly.

They should have lubricant on them at all times and not be operated dry.

Linkage - All linkage joints and pivot points (including levers & side stand) must be lubricated to maintain a smooth operation.

Maintenance

Battery/Electrical

Battery - Your Megelli bike is fitted with a sealed battery which doesn't require any maintenance.

If the bike has not been used for a month, it should be charged by a battery charger suited to a sealed type of battery.

If the bike is not to be used for periods in excess of 2 months, it should be removed and stored fully charged, in a cool and dry place.

The battery should be charged every 2 months to maintain a full charge.

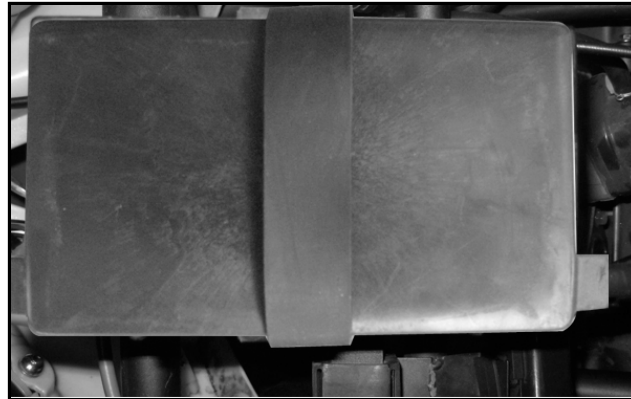

▲ Warning Batteries contain acid and should be handled with care.

▲ Warning Expired batteries should be disposed of in accordance with local legislation.

! Caution When conducting repairs, in particular electrical repairs, always disconnect the battery.

Maintenance

Battery/Electrical

Fuse - The electrical circuit is protected by a fuse. The electrical circuit is protected by a fuse. The fuse is installed on top of starter relay where located inside of fuel tank left panel. To access the fuse by removing the fuel tank left panel. If the fuse has blown, always replace it with a fuse of the same rating(20A) If it continues to blow, have the bike checked by a Megelli dealer to establish the reason and take action to prevent recurrence.

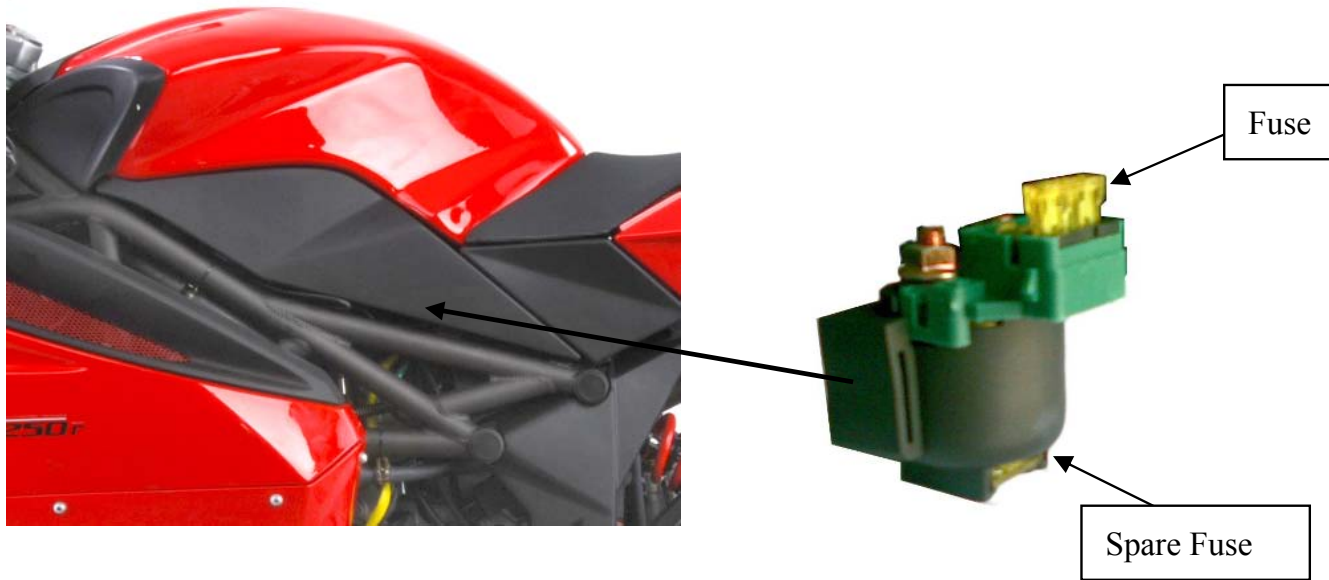

For any further electrical issues, with the exception of lights, please consult a Megelli dealer.

Maintenance

Bulbs

Headlight - This is fitted with a halogen bulb. It is important it is not touched with bare skin or be contaminated with any form of grease. Any such contamination will reduce the performance and the life expectancy of the bulb.

! **Caution** - bulbs do become very hot and you should not work with them until they have cooled!

▲ **Warning** - do not replace the bulb with a higher wattage unit

▲ **Warning** - do not place any tinted cover or decal over the lens.

To replace the bulb:-

- 1) Disconnect the electrical plug
- 2) Remove the headlight rubber cover
- 3) Unclip the bulb and remove
- 4) Fit a new bulb and secure it using the reverse order of removal.



Maintenance

Bulbs

Side Light

- 1) Remove light holder with bulb still fixed.
- 2) Pull the bulb from the holder and replace with new bulb.
- 3) Replace using the reverse of removal.



Maintenance

Bulbs

Indicator:

The indicators use LED, and can only be replaced as an assembly.

Removal:

- 1) Disconnect the electrical connector.
- 2) Pull the unit off the rubber mount.

Replacement:

- 1) Feed wire through rubber mount and connect to main wiring connector.
- 2) Push unit into rubber mount.



Maintenance

Bulbs

Tail/Brake Light

! Caution - ensure the exhaust is cool prior to working on the rear light.
The tail/brake light uses LED's and can only be replaced as an assembly.

Removal:

- 1) Remove seat (page 40).
- 2) Disconnect electrical connector.
- 3) Remove 2 nuts securing the light shroud and assembly.
- 4) Pull the light assembly to rear to remove.

Replacement:

-use the reverse procedure of removal.



Maintenance

Bulbs

License Plate Light

! Caution - ensure the exhaust is cool prior to working on the rear light.

- 1) Remove fixing bolt securing the assembly and unplug the cable/wiring .
- 2) Replace the assembly complete.

Maintenance

Air Filter

The air filter is located under the seat. To access the filter, remove the seat (see page 38) .

Remove the lid from the air clearer assembly which is secured by 4×screws. The filter can then be lifted out of the assembly.

Under normal operating conditions, the filter requires no maintenance outside of the normal servicing schedule. If however, the bike is used in conditions where the filter is contaminated with foreign material, it may require additional inspection.

Filter inspection - Remove retaining screws from the air filter housing. Remove the element and inspect for contamination. Contamination can be removed by using low pressure air stream or gently tapping the filter.

▲ Warning -Do not use high pressure air stream or hit the filter aggressively against a hard surface as it may damage the component and not function correctly.

If there is excessive contamination, replace the element.

▲ Warning -Do not operate the bike without a filter correctly in place.

Maintenance

Wheels/Steering

- Prior to every ride, the steering should be checked to ensure there is a smooth action turning the handlebars from one full lock to the other.
- To check the steering bearings, apply the front brake to prevent the wheel from turning. Rock the bike to and fro, feeling for any movement/play in the bearings.



Maintenance

- To check the wheel bearings, raise the respective wheel off the ground and ensure the bike is stable. The wheel should rotate freely.
- Grip the wheel and rock from side to side, checking for movement/free play at the hub/bearings.



If there is any free play, have the bike checked by a Megelli dealer.

- Inspect the rims before each ride for any form of damage. Any dents, cracks or defects should be checked by a Megelli dealer.

Maintenance

Tyres

The condition of the tyres should be checked prior to every ride.

- Check tyres for damage including cuts, splits or bulges
- Check air pressure (see capacities)
- Ensure there is sufficient tread to meet legal requirements
- Check there are no foreign bodies embedded in the tyres

▲ **Warning** – Riding with a defective tyre may impair the handling and performance of the motorcycle resulting in serious safety issues

Technical Specification

Note: Specifications are subject to change without prior notice.

Engine

Cylinder Arrangement	Single Cylinder
Cooling system	Liquid Cooled
Compression Ratio	11.5:1
Carburetor Type	TK MV34
Idle Speed(rpm)	1500±100
Valve Train	SOHC
Lubrication System	Forced and Wet Sump
Maximum Speed	140KM/h
Oil Capacity	1500ml
Starter System	Electric System

Technical Specification

Transmission

Clutch	Wet Type and Multi-Plates
Gear Box	6 Speed Gear Change
Gear Ratios-1st	2.583
-2nd	1.800
-3rd	1.333
-4th	1.100
-5th	0.958
-6th	0.880
Primary Reduction	2.909
Final Reduction	2.846(37/13)
Gear Shift pattern	1-N-2-3-4-5-6
Final Drive Type	Chain
Final Drive	Cushioned
Sprocket	520-37T

Technical Specification

Electrical

Generator	12 pole three-phase full-wave DC Generator
Ignition	C.D.I
Starter	Electrical Starter
Battery	12V8AH Sealed Maintenance Free
Spark plug	RG6YC
Fuse	20A
Bulb – Headlight(high beam)	12V 55W
Headlight(dipped)	12V 55W
Tail Light	12V 0.23W-LED
Rear Brake Light	12V 0.58W-LED
Indicator	12V 2W- LED
Side	12V 5W
License Plate	12V 5W

Technical Specification

Dimensions

Overall Height	1060mm
Overall Length	1990mm
Overall Width	780mm
Seat Height	800mm
Wheel Base	1350mm
Ground Clearance	150mm
Weight(Dry)	135Kg
Maximum Weight	280Kg

Technical Specification

Chassis

Frame - Type - Steering Head Angle	Multi Twin Spar Trellis Configuration 30 Degree
Suspension -Front - Rear	Conventional Fast Ace – Mono-Shock
Wheel-Front Rim -Rear Rim	Cast Aluminium Rim 2.75 - 17 Cast Aluminum Rim 3.50-17
Tyre-Front -Rear -Front Tyre Pressure -Rear Tyre Pressure	CST 100/70-17TL-Tubeless CST 130/70-17TL- Tubeless 200Kpa (28P.S.I.) 220Kpa (32 P.S.I.)
Chain-Pitch - Number of Links	520 104

Technical specification

Capacities

Fuel Tank-Full	11 litre
-Reserve	1 litre
Engine Sump	1.5 litre
Brake Fluid	DOT4 or DOT3

Technical specification

Fluid Grade

Fuel	Unleaded with min. octane #90
Oil	SJ 5W-40
Brake	DOT4 or DOT3
Chain Lubricant	Bespoke chain lubricant or SAE 80 or 90 weight gear oil

Cleaning/Care

Regular cleaning will extend the life of your Megelli motorcycle and help retain its value.

Before cleaning your motorcycle we recommend you cover the exhaust pipe to prevent water entering and causing damage.

Wash the motorcycle with a soft sponge and plenty of warm water. A mild solution designed for cleaning motorcycles may be used to aid the cleaning process. Ensure the sponge and water is clean and not contaminated with abrasives as this may damage/ scratch the surface of the bike, particularly plastic bodywork and the transparent wind shield. Rinse with clean warm water and finally dry with a polishing cloth or chamois leather.

Using a chain and or engine cleaner/ degreasing agent will assist in the removal of excess grease/ Lubricant. These must be used according to the manufacture's instructions and any detrimental effect is out of the control of Megelli.

Cleaning/Care

- ▲ **Warning** Avoid applying polish/wax or any substance to the contact points eg seat, handlebar grips which will make them slippery.

- ! **Caution** When using proprietary cleaners, ensure they do not have an adverse effect on the area being cleaned.

- ! **Caution** Do not use a high pressure washer as this may cause damage to the seals, drive chain and the electrical system..

- ! **Caution** Always carry out a brake test after cleaning as the braking systems may still be damp which may lengthen the braking distance.

Storage

If the motorcycle is not going to be used for more than 30 days, it is advisable to perform the following to ensure it does not deteriorate.

- Wash and thoroughly clean the bike (see Cleaning/ Care section).
- Fill the tank with fuel .
- Ensure the bike is dry .
- Ensure the chain and all moving parts are sufficiently lubricated (see lubrication section).
- Apply a protective wax, avoiding all contact points eg seat, handlebar grips, foot rests etc.
- Fully inflate the tyres (see capacities). If possible remove the weight from the wheels by the use of a bike stand.
- Remove and charge the battery. The charge on the battery should be topped up every month using a suitable battery charger.
- Store in a dry well ventilated building.
- If a cover is used, ensure it is designed for motorcycles, preventing a build up of moisture.

Warning

- After storage, replace the battery.
- Clean the bike .
- Perform the standard pre-ride checks.
- Start the bike and initially ride at low speed to ensure all aspects of the bike are functioning correctly

Care for the Environment

By riding a Megelli you are already using an environmentally friendly form of transport and contributing to congestion reduction. Megelli is conscious of the effect transport has on the environment and strives to produce efficient motorcycles during their working life and also in the production process.

We respectfully ask owners of Megelli motorcycle to ride efficiently, conserving fuel where possible and care for the environment. All waste oils, fluids and replaced components should be disposed of in accordance with local legislation.

Parts

Genuine Megelli parts should always be used to replace any items on your Megelli motorcycle. Use of non-genuine parts may have an adverse effect on the performance of the bike and their use will invalidate any warranty.

Genuine parts can be sourced from authorized Megelli dealers and can be viewed at www.megelli-parts.com

Warranty

The terms of the warranty offered with Megelli motorcycles are detailed within the 'Warranty information and Service Schedule' booklet which should accompany the motorcycle for the duration of its life. The terms explained in this booklet must be adhered to so in the event any item requires replacing or rectification, it can be conducted within these terms, with the minimum of disruption.

Maintenance Schedule Summary

The following tables indicate the minimum intervals for checks and lubrication. – marked X. Further details can be found in the specific section in the manual.

Table 1: lubrication

Items \ Interval	6,000 kms (4,000 miles) OR 6 months	12,000 kms (8,000 miles) OR 12 months
Throttle Cable	X	
Throttle		X
Clutch Cable	X	
Drive Chain	Every 1000kms (600 miles) OR week OR after washing or use in rain	
Brake Pedal Collar	X	
Gear change Collar	X	
Steering bearing	10,000 kms (6000 miles) OR 12 months	
Swingarm Spacers	10,000 kms (6000 miles) OR 12 months	

Maintenance Schedule Summary

Table 2: Checks

Items \ Period	Initial 1,000kms (600 miles) OR 3 months	4,000kms (2500 miles) OR 12 months	7,000kms (4500 miles) OR 24 months
Cylinder Head bolts and Exhaust pipe bolts	X	X	
Cam Chain	Tighten	Tighten	
Air Cleaner	3000km		
Valve Gap	X	X	
Spark Plug		X	
Fuel Hose	X	X	
	Replace every four years		
Oil	X	Every 3000km (2000 miles)	
Oil Filter	X	X	
Carburetor	X	X	
Clutch	X	X	
Fuel Filter		X	Replace

Maintenance Schedule Summary

Table 2: Checks (continued)

Items \ Period	Initial 1,000kms (600 miles) OR 3 months	4,000kms (2500 miles) OR 12 months	7,000kms (4500 miles) OR 24 months
Drive Chain	X	X	
Brake Hoses	X	X	
	Replace every 4 years		
Brake Oil	Replace every 2 years		
Brakes	X	X	
Tyres	X	X	
Steering System	X	X	
Front and Rear suspension	X	X	
Bolts and Nuts	X	X	

WWW.

Megelli

.COM